

**NACHI**

**PZS SERIES  
VARIABLE VOLUME PISTON PUMP**

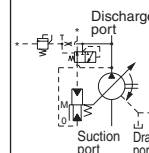

**A  
Piston Pumps**

**PZS Series  
Variable Volume Piston Pump**

**70 to 220cm<sup>3</sup>/rev  
70 to 100cm<sup>3</sup>/rev 28MPa  
130 to 220cm<sup>3</sup>/rev 25MPa**

**Features**

**① High pressure, high reliability**

These pumps deliver the perfect combination of high pressure (28MPa {286kgf/cm<sup>2</sup>} maximum) and high reliability. Hydraulic device energy efficiency is ensured because variable volume capabilities provide the means to keep the discharge rate to the desired level.

**② Low noise, low vibration operation**

The semi-cylindrical swash plate of

the PVS series provides high support and rigidity, making it possible to increase the number of pistons (from nine to 11) and equip optimal valve plates, all of which make low-noise operation possible.

**③ High reliability, long life**

O-ring seals used for mating surfaces eliminate worries about oil leaks. A spherical valve plate maintains optimal hydraulic pressure balance, for

stable operation across a wide range and better contamination resistance characteristics.

**③ A wide range of possible applications**

In addition to use as a stand-alone pump, a PVS Series pump can be combined with another IP pump in a wide range of possible applications.

**Specifications**

Model No.	Pump Capacity cm <sup>3</sup> /rev (Adjustment Range)	Rated Voltage MPa {kgf/cm <sup>2</sup> }	Maximum Working Pressure MPa {kgf/cm <sup>2</sup> }	Pressure Adjustment Range MPa {kgf/cm <sup>2</sup> }	Revolution Speed min <sup>-1</sup>		Weight kg	Fixed Discharge Pump (Note 1)	
					Min.	Max.		Capacity cm <sup>3</sup> /rev	Pressure MPa {kgf/cm <sup>2</sup> }
PZS-3B-70* 1-10 3 4	70 (45 to 70)	21 {214}	28 {286}	2 to 7 {20.4 to 71.4} 2 to 21 {20.4 to 214 } 2 to 28 {20.4 to 286 }	500	1800	37	3.6 to 15.8 (IPH-2.3 type)	21 {214}
PZS-4B-100* 1-10 3 4	100 (40 to 100)	21 {214}	28 {286}	2 to 7 {20.4 to 71.4} 2 to 21 {20.4 to 214 } 2 to 28 {20.4 to 286 }	500	1800	58	3.6 to 15.8 (IPH-2.3 type)	21 {214}
PZS-5B-130* 1-10 3 4	130 (51 to 130)	21 {214}	25 {255}	2 to 7 {20.4 to 71.4} 2 to 21 {20.4 to 214 } 2 to 25 {20.4 to 255 }	500	1800	86	3.6 to 32.3 (IPH-2.3.4 type)	21 {214}
PZS-6B-180* 1-10 3 4	180 (101 to 180)	21 {214}	25 {255}	2 to 7 {20.4 to 71.4} 2 to 21 {20.4 to 214 } 2 to 25 {20.4 to 255 }	500	1800	123	3.6 to 63.9 (IPH-2.3.4.5 type)	21 {214}
PZS-6B-220* 1-10 3 4	220 (124 to 220)	21 {214}	25 {255}	2 to 7 {20.4 to 71.4} 2 to 21 {20.4 to 214 } 2 to 25 {20.4 to 255 }	500	1500	126	3.6 to 63.9 (IPH-2.3.4.5 type)	21 {214}

Note 1. Fixed discharge pump can be configured by combining with an IP pump.  
2. Pump capacity adjustment ranges are for control codes N, RS, and WS. For information about control code NQ, see page A-27.  
3. Direction of rotation is clockwise when viewed from the shaft end.

- Handling
- Pump Installation and Piping Precautions

- ① Use flexible couplings for connecting the pump shaft to the drive shaft, and prevent radial or thrust load from being applied to the pump shaft.
- ② Eccentricity between the drive shaft and pump shaft should be no greater than 0.05mm, with an eccentric angle error of 1° or less.
- ③ Keep the clamping length of couplings and pump shafts at least 2/3 the length of the coupling width.
- ④ Use a sufficiently rigid pump mounting base.
- ⑤ Set pump suction side pressure to -0.03 MPa or more (suction port flow velocity less than 2 m/sec).
- ⑥ Raise part of the drain piping so it is above the topmost part of the pump body, and insert the return section of

the drain piping into the hydraulic operating fluid. Also, observe the values in the following table in order to limit the drain back pressure to 0.1 MPa.

Model No.	3B, 4B, 5B	6B
Pipe joint size	At least 3/4"	At least 1"
Pipe I.D.	At least φ17	At least φ22
Pipe length	1 m or less	1 m or less

- ⑦ Mount the pump so the pump shaft is oriented horizontally.
- ⑧ Use of rubber hose is recommended in order to minimize noise and vibration.
- ⑨ Check valve is located on the discharge side of the pump. (To prevent reverse rotation and damage to the pump when it is off)

- Management of Hydraulic Operating Fluid

- ① Use only good-quality hydraulic operating fluid with a kinematic viscosity during operation within the range of 20 to 200 mm<sup>2</sup>/sec. Normally, you should use an R&O type and wear-resistant type of IS-OGV32 to 68 or equivalent. The optimum kinematic viscosity during operation is 20 to 50 mm<sup>2</sup>/sec.
- ② The operating temperature range is 5 to 60°C. When the oil temperature at startup is 5°C or less, run the pump at low pressure and low speed until the oil temperature reaches 5°C.
- ③ Provide a suction strainer with a filtering grade of about 100μ (150 mesh).

(Continued on following page)

- 4 Manage hydraulic operating fluid so contamination is maintained at class NAS10 or lower.
- 5 Use hydraulic operating fluid when the operating ambient temperature is in the range of 0 to 60°C.

• Startup Precautions

- 1 Before starting up the pump, fill the pump body with clean hydraulic operating fluid through the lubrication port.

Model No.	Oil Amount cm <sup>3</sup>
PZS-3B	1000
PZS-4B	1800
PZS-5B	2200
PZS-6B	3000

- 2 An unload circuit is required when the motor is started under condition  $\lambda-\Delta$ . Contact your agent about the unload circuit.

- 3 Check to make sure that the rotation direction of the pump is the same as the rotation direction indicated by the arrow on the pump body.
- 4 Air entering the pump or pipes can cause noise or vibration. At startup, set the pump discharge side to a no-load state, and operate the pump in the inching mode to remove any air that might be in the pump or pipes.
- 5 Equip an air bleed valve in circuits where it is difficult to release air before startup. (See "IP Pumps" on page C-13.)
- 6 Install a check valve on the discharge side to protect the pump if the load is large or if there is an accumulator in the circuit on the discharge side of the pump.
- 7 Do not release the pressure in the hydraulic circuit by switching the solenoid valve (RS/WS type) on the pump.

- Configuring Pressure and Discharge Rate Settings  
The factory default pump discharge rate setting is the setting's maximum value, while the default discharge pressure is the settings minimum value. Change the discharge rate and discharge pressure settings in accordance with your particular operating conditions.

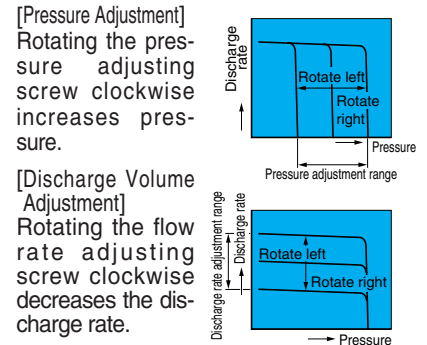

Note: Securely tighten the lock nut after making adjustments.

## Understanding Model Numbers

Standard type

Pressure compensation(N)

**PZS - 4 B - 100 N \* - 10**

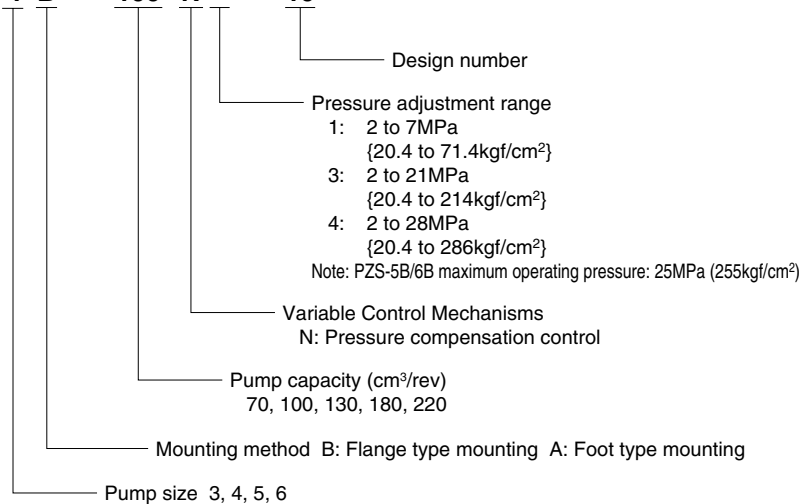

Option type

2-Pressure, 2-Flow Rate Control Type (NQ)

**PZS - 4 B - 100 N \* Q \* - 10**

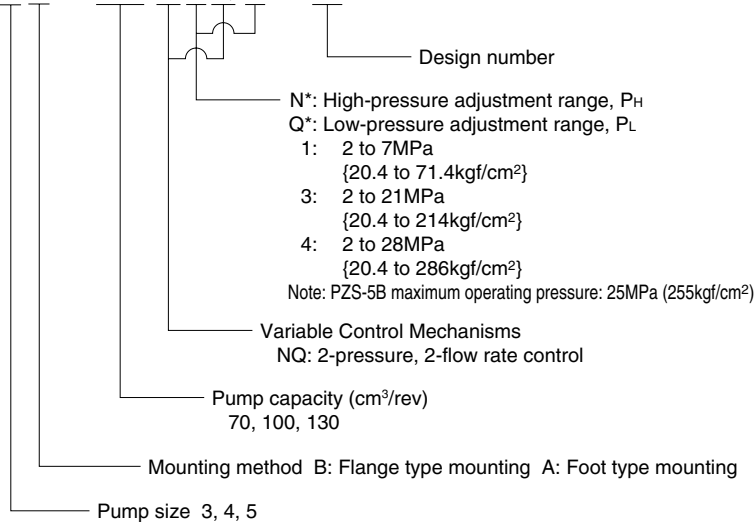

### P-Q characteristics

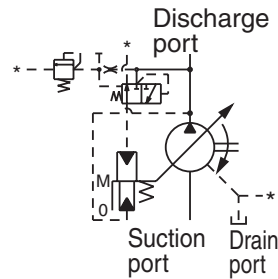
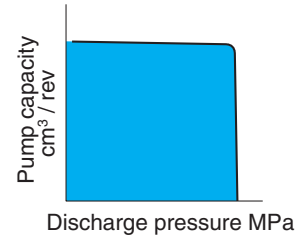

### P-Q characteristics

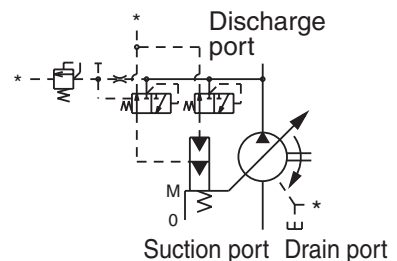
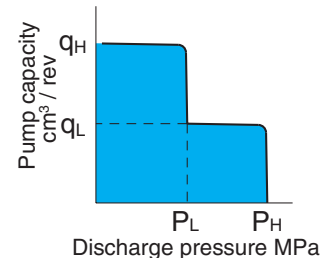

Solenoid Cutoff Control Type (RS)

**PZS - 4 B - 100 R \* S \* - 10**

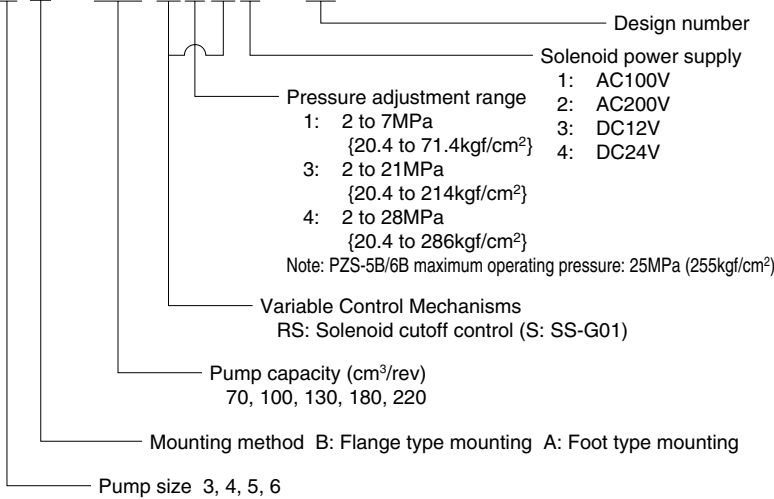

P-Q characteristics

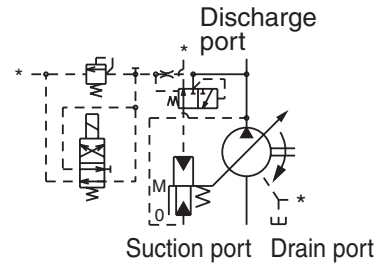
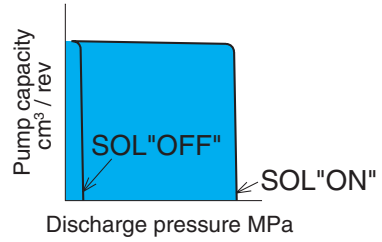

Do not use the solenoid valve to release the pressure in the hydraulic circuit.

2-Pressure Control System (WS)

**PZS - 4 B - 100 W \* S \* - 10**

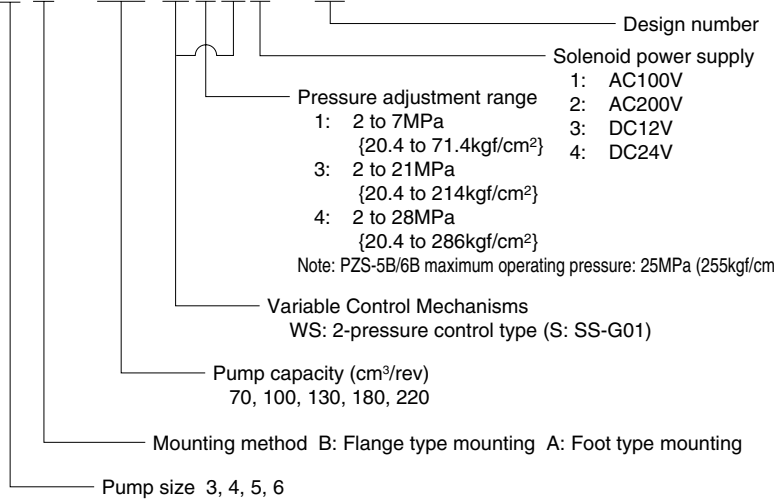

P-Q characteristics

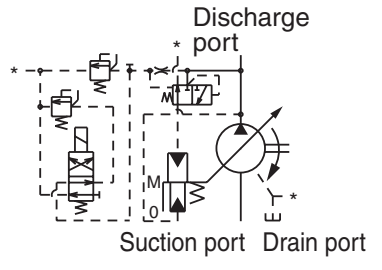
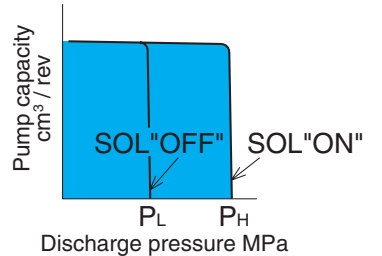

**Installation Dimension Drawings**

Pressure Compensation Type

Installing a remote control relieve valve to the pilot port provides remote control of pressure compensation. (PVS series "P type")

PZS-3B-70N\*-10

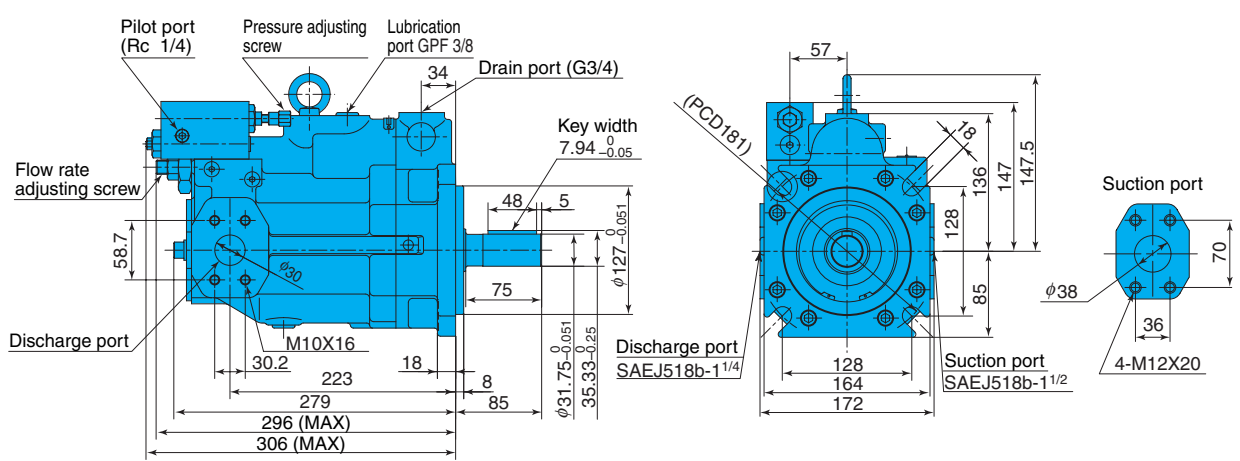

**PZS-4B-100N\*-10**

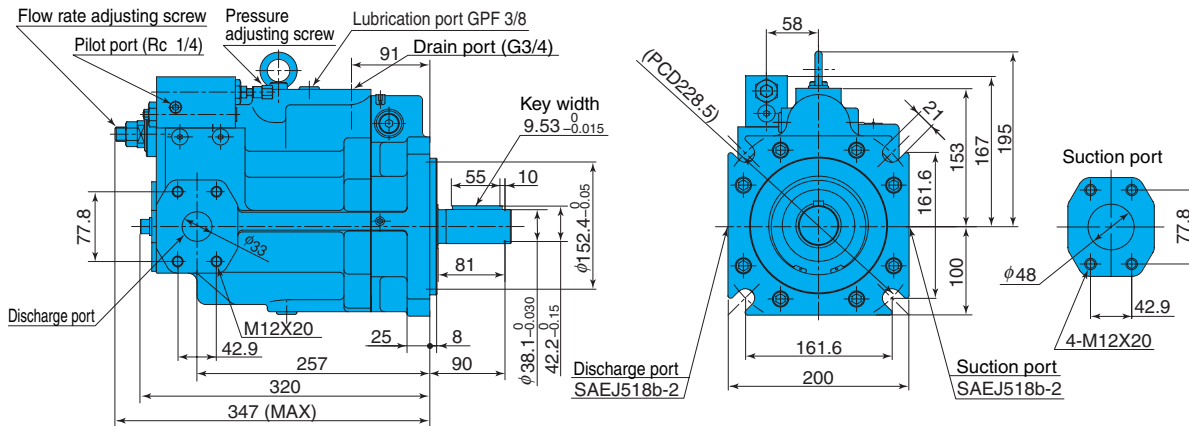

**PZS-5B-130N\*-10**

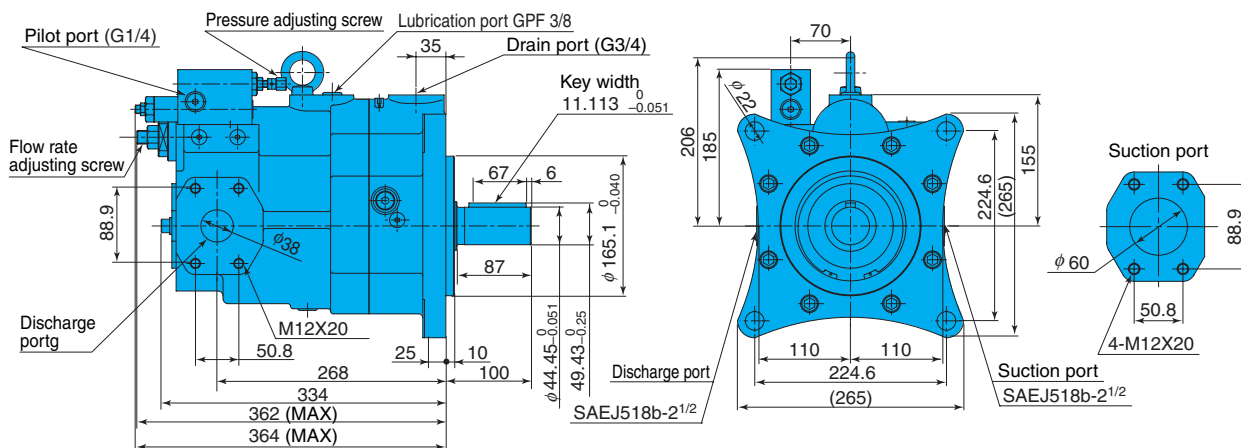

**PZS-6B-180N\*-10**

**PZS-6B-220N\*-10**

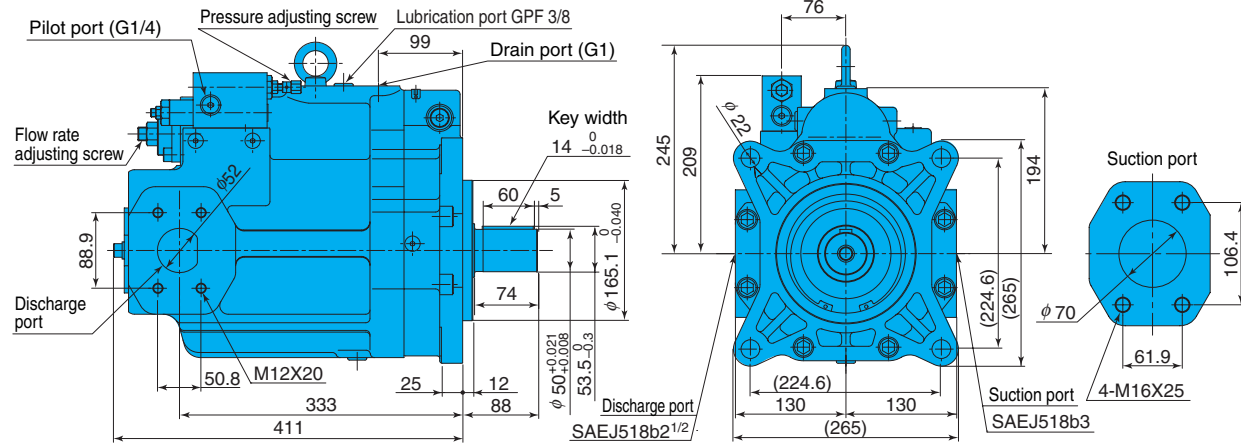

**Flow Adjustment Rotation Angle (  $\ell$  ) and Pump Capacity ( q )**

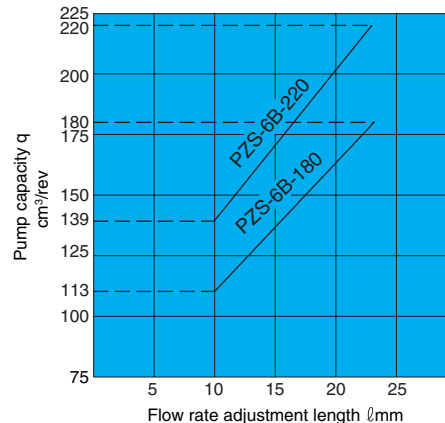
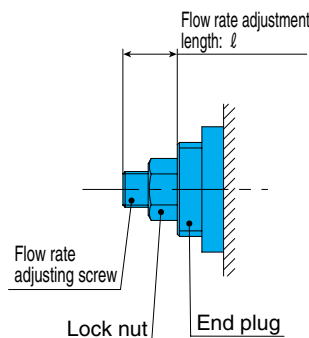
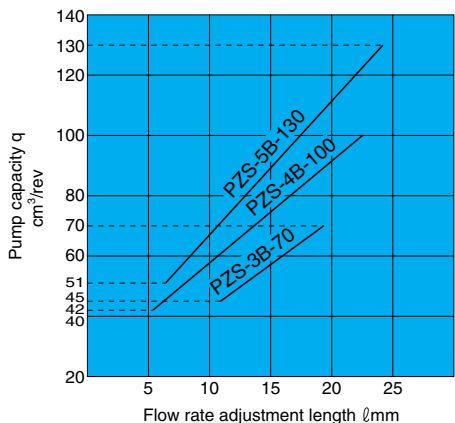

Use a flow adjustment length that is within the range noted in the above chart. Using a length that is outside the lower limit adjustment range can lead to oil leaks.

Use a flow adjustment length that is within the range noted in the above chart. Using a length that is outside the lower limit adjustment range can lead to oil leaks.

2-Pressure, 2-Flow Rate Control Type  
PZS-3B-70N\*Q\*-10

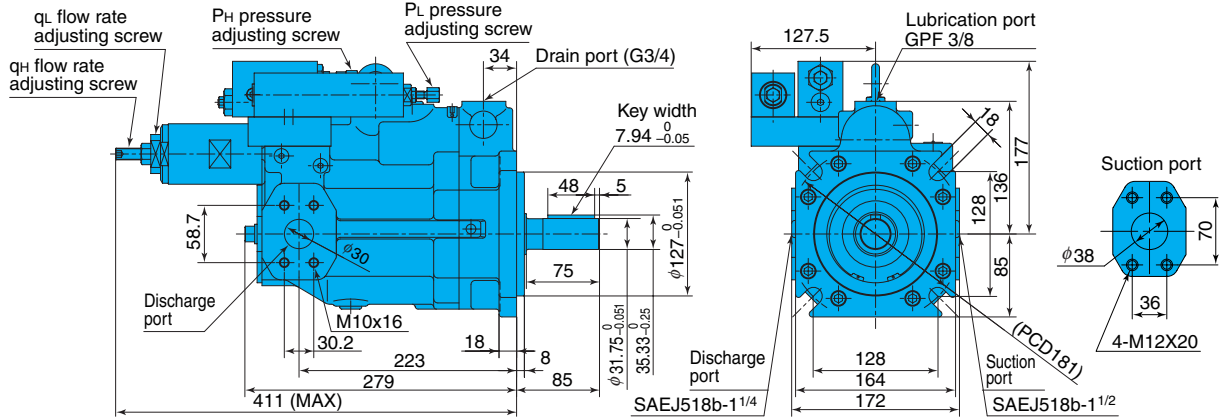

PZS-4B-100N\*Q\*-10

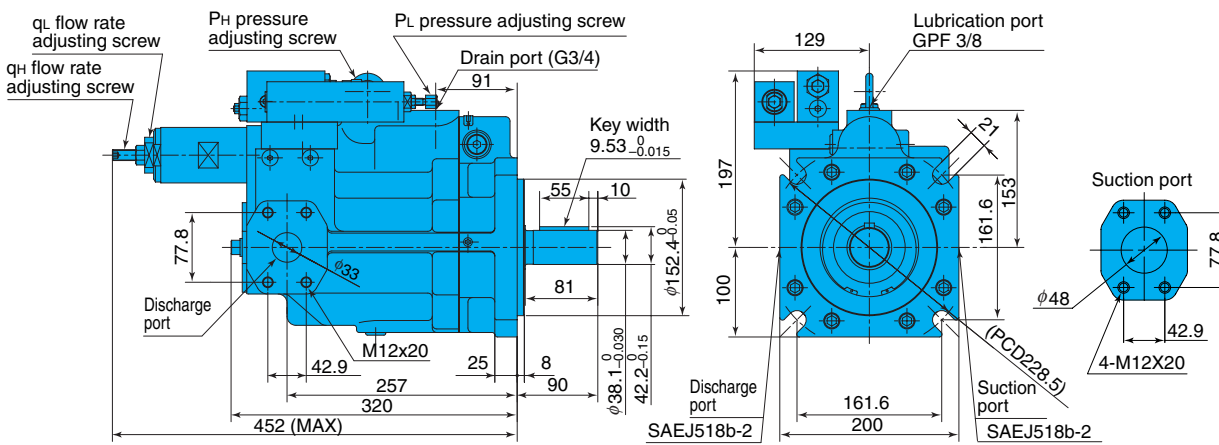

PZS-5B-130N\*Q\*-10

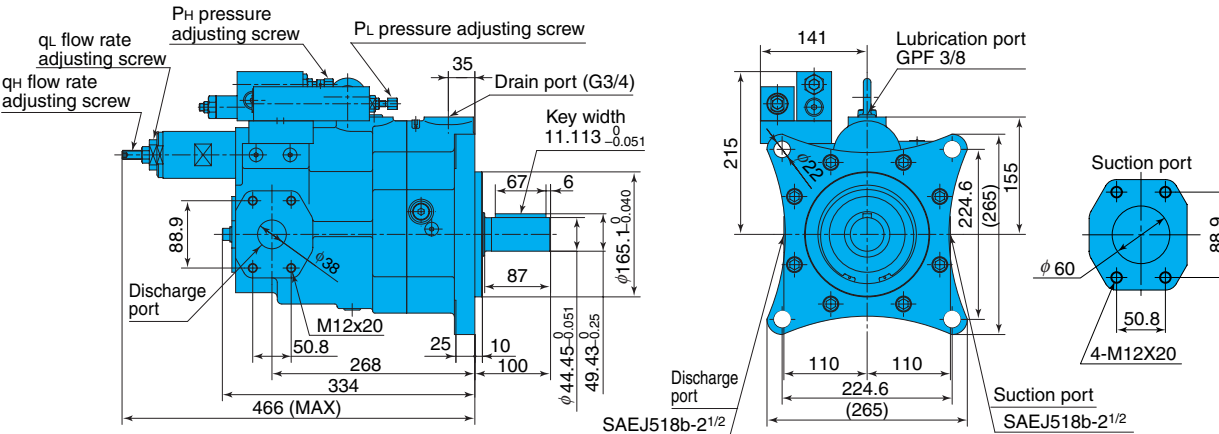

Pump Volume Adjustable Range

Pump Model No.	Volume Adjustment Range cm <sup>3</sup> /rev		Factory Default q <sub>e</sub> Setting (cm <sup>3</sup> /rev)
	q <sub>H</sub> Note 1	q <sub>L</sub> Note 2	
PZS-3B-70N*Q*-10	5 to 70	5 to 40	14
PZS-4B-100N*Q*-10	16 to 100	7 to 60	20
PZS-5B-130N*Q*-10	17 to 130	8 to 70	26

Note1: The setting range for pump maximum capacity q<sub>H</sub> depends on the q<sub>e</sub> setting.  
 Note2: Overall efficiency at a low flow rate is worse than at the maximum flow rate. Keep this in mind when deciding on the drive motor capacity.  
 Note3: P<sub>L</sub> is set to 3.5 MPa before shipping. (P<sub>H</sub> is the lowest pressure)

P-Q characteristics

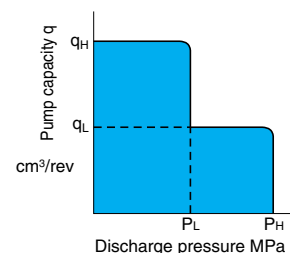

PZS Pump 2-Pressure 2-Flow Rate Control Flow Rate Adjustment Graph

- Be sure to adjust the low flow rate first, and then adjust the maximum flow rate.
- Remember that the maximum flow rate adjustment range (lower limit) changes in accordance with the low flow rate adjustment. The maximum flow rate adjustment lower limit is equivalent to the low flow rate adjustment length (L1) plus 11 mm.
- Pump efficiency at a low flow rate is worse than at the maximum flow rate. Keep this in mind when deciding on the drive motor capacity.

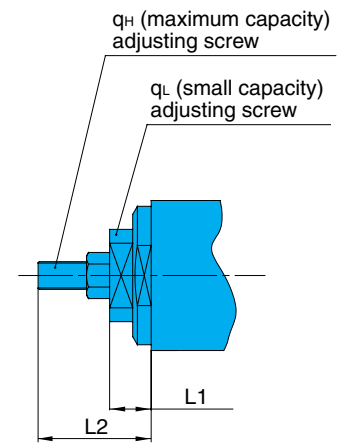
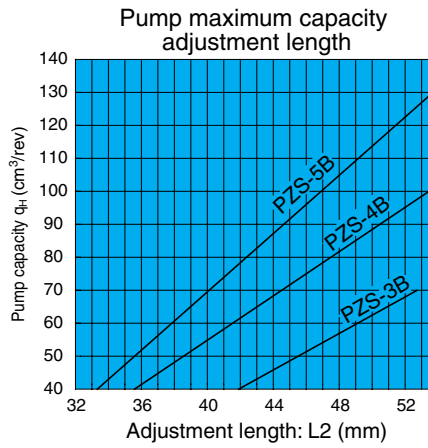
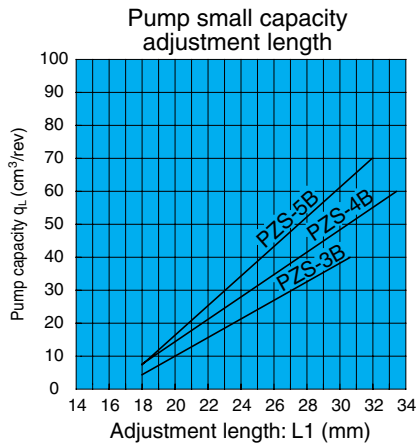



Solenoid Cutoff Control Type  
PZS-3B-70R\*S\*-10

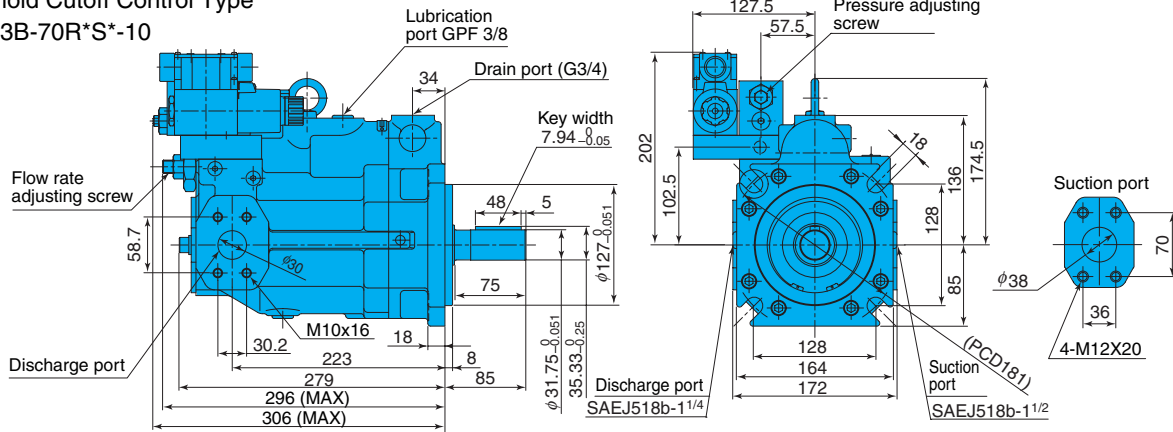

PZS-4B-100R\*S\*-10

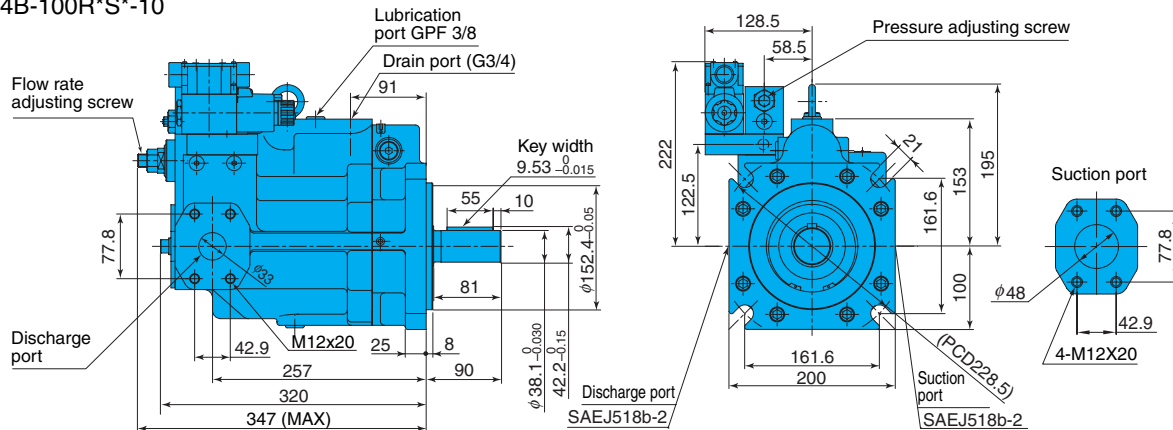

PZS-5B-130R\*S\*-10

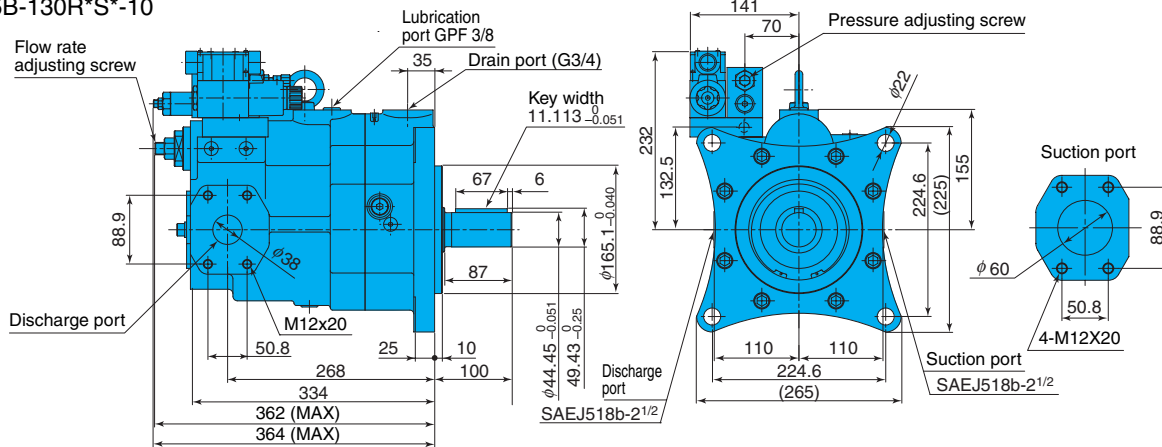

PZS-6B-180R\*S\*-10

PZS-6B-220R\*S\*-10

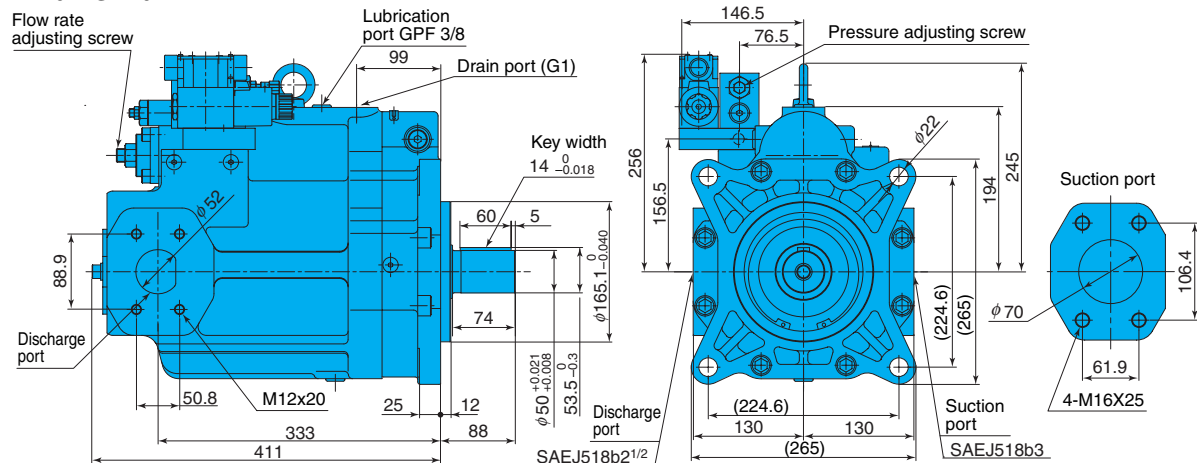

- Using the installed solenoid valve so it is continuously conducting current can cause the coil surface to become hot. Do not touch the surface of the coil directly with your hands.
- Do not use the solenoid valve to release the pressure in the hydraulic circuit.

2-Pressure Control Type  
PZS-3B-70W\*S\*-10

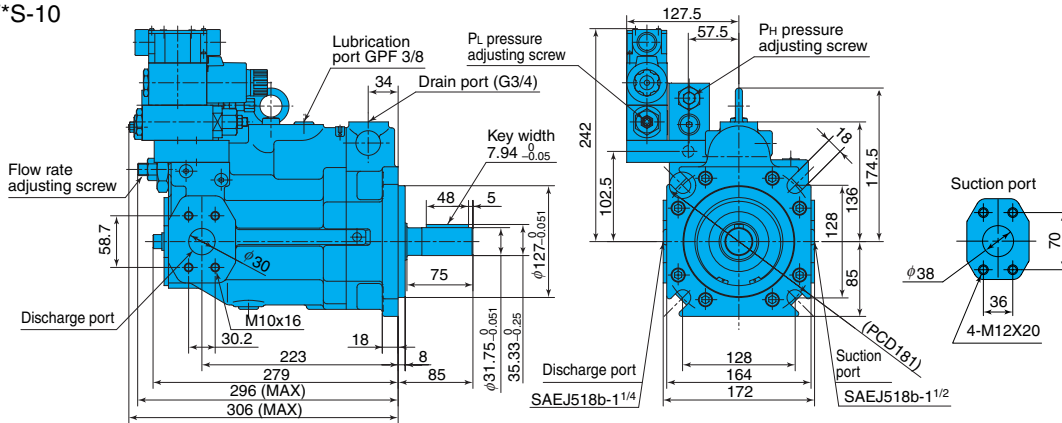

PZS-4B-100W\*S\*-10

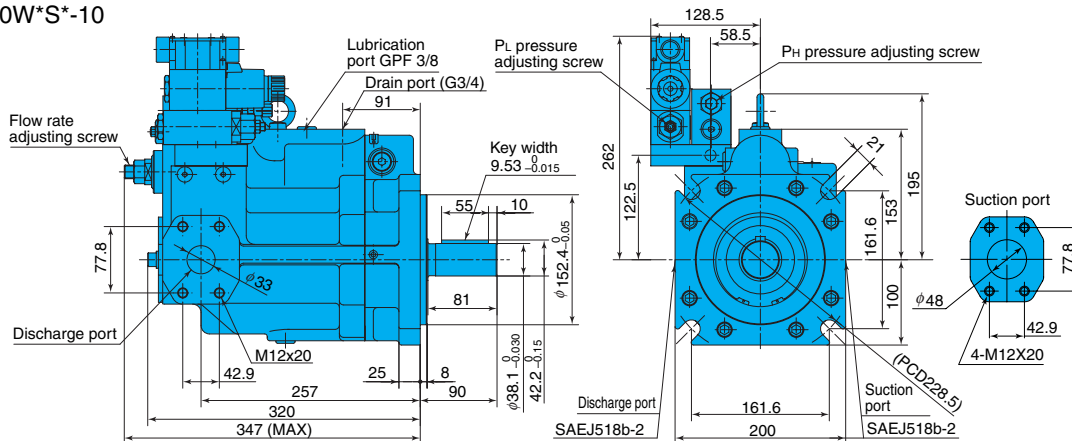

PZS-5B-130W\*S\*-10

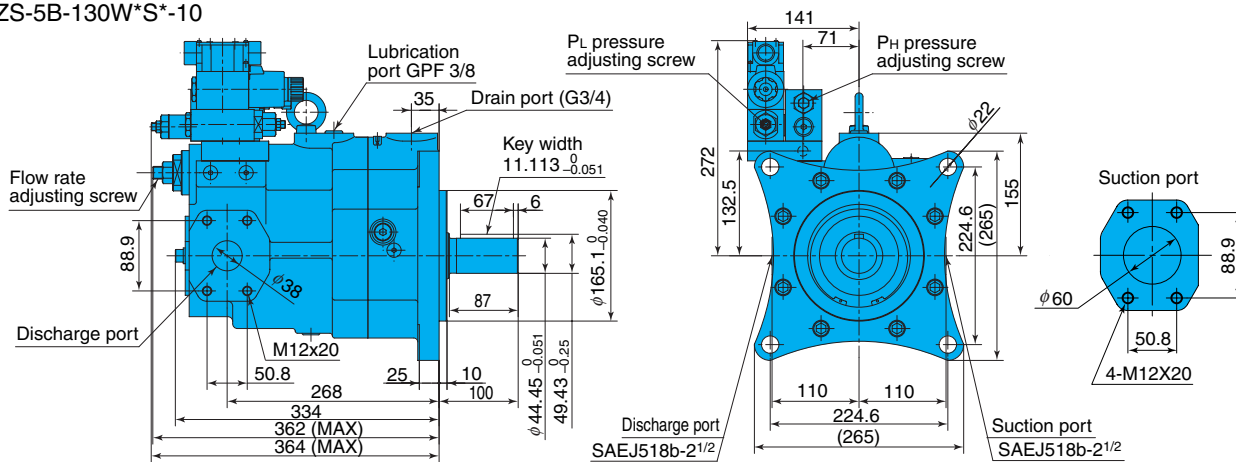

PZS-6B-180W\*S\*-10

PZS-6B-220W\*S\*-10

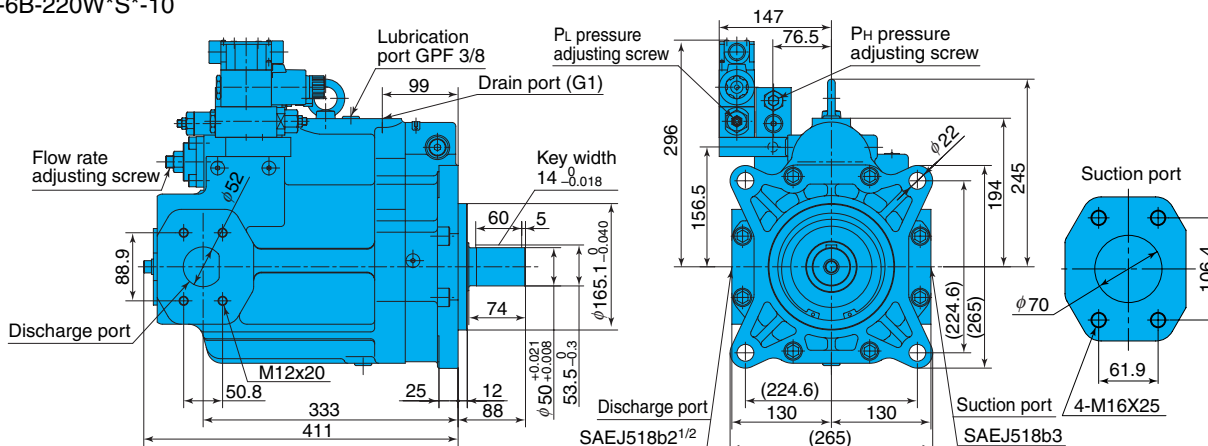

- Using the installed solenoid valve so it is continuously conducting current can cause the coil surface to become hot. Do not touch the surface of the coil directly with your hands.
- Do not use the solenoid valve to release the pressure in the hydraulic circuit.



**Performance Curves**

Typical Characteristics at a Hydraulic Operating Fluid Kinematic Viscosity of 46 mm<sup>2</sup>/s

PZS-3B-70N\*-10

General Performance

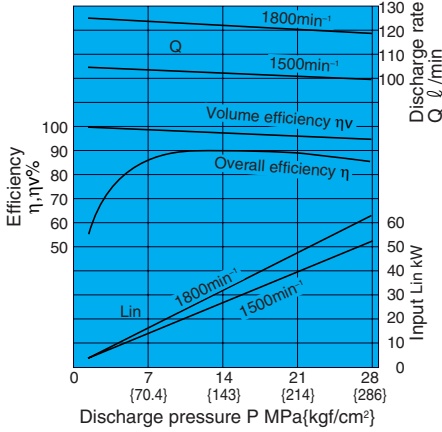

Pressure - Flow Rate Characteristics

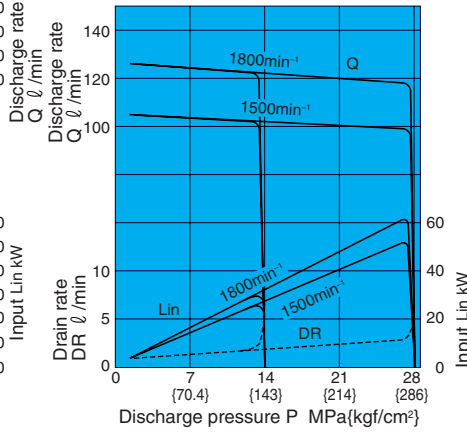

Axial input

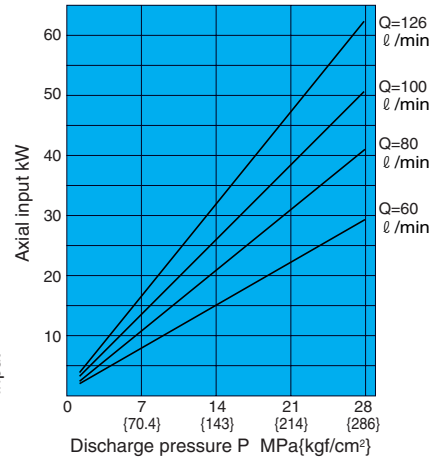

Axial Input at Full Cutoff

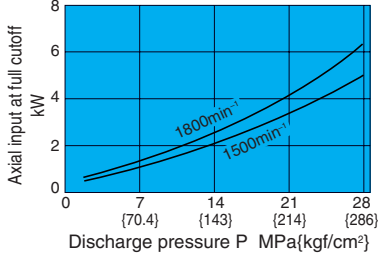

Noise Characteristics

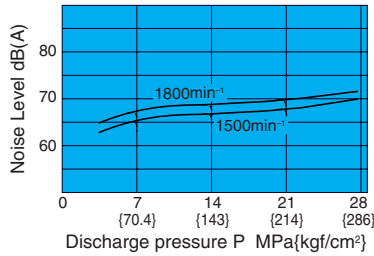

PZS-4B-100N\*-10

Typical Characteristics at a Hydraulic Operating Fluid Kinematic Viscosity of 46 mm<sup>2</sup>/s

General Performance

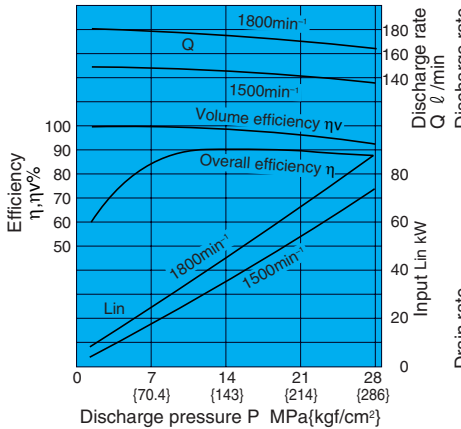

Pressure - Flow Rate Characteristics

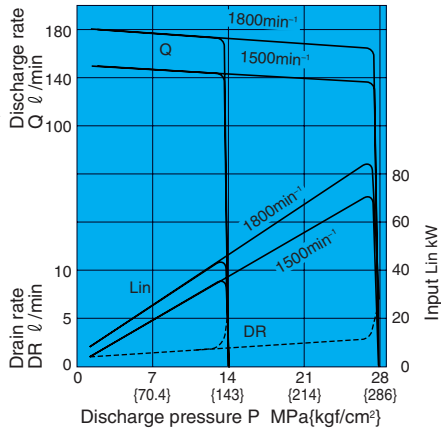

Axial input

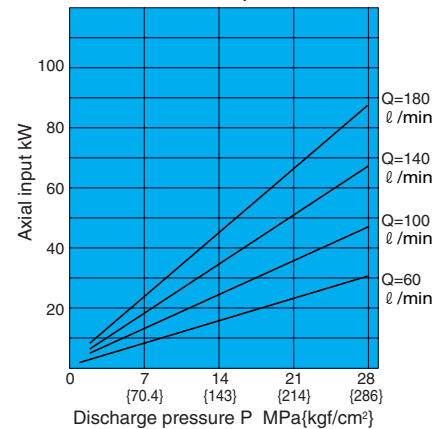

Axial input at full cutoff

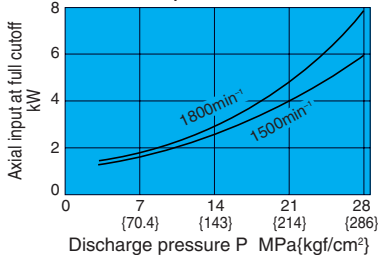

Noise Characteristics

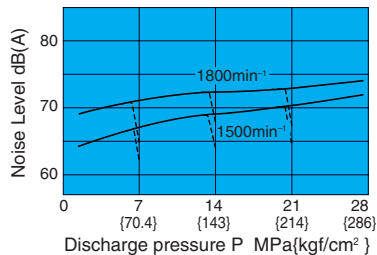

PZS-5B-130N\*-10

Typical Characteristics at a Hydraulic Operating Fluid Kinematic Viscosity of 46 mm<sup>2</sup>/s

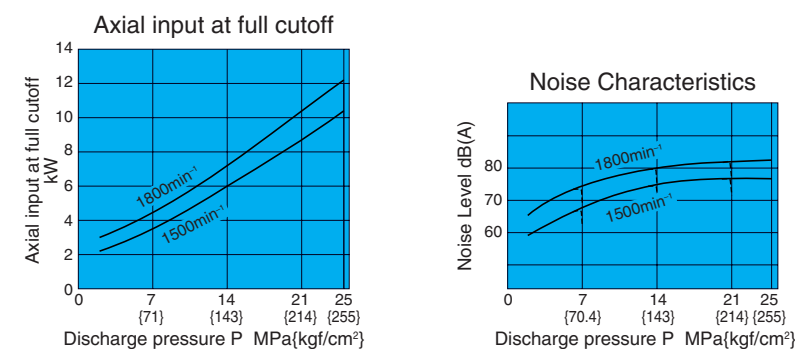
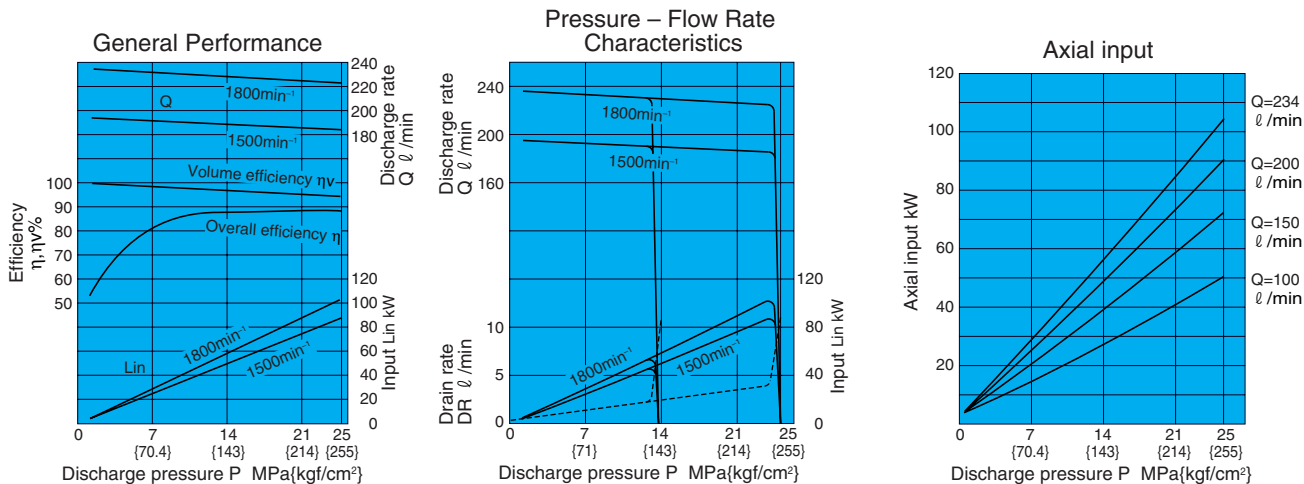

PZS-6B-180N\*-10

Typical Characteristics at a Hydraulic Operating Fluid Kinematic Viscosity of 46 mm<sup>2</sup>/s

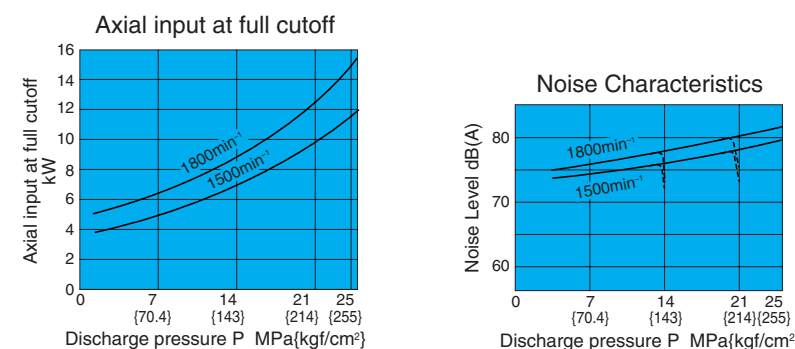
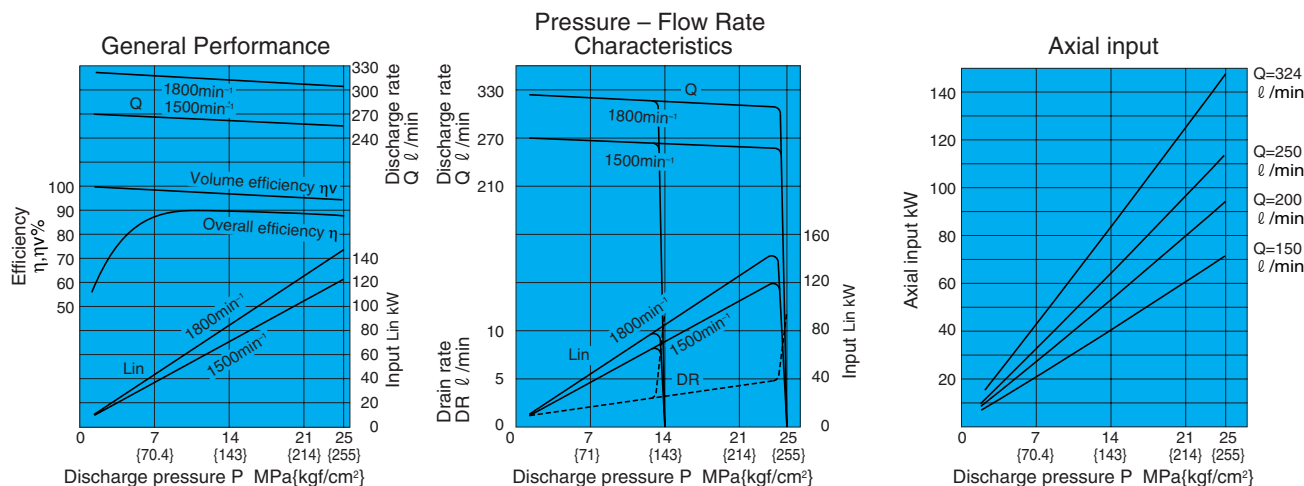

PZS-6B-220N\*-10

Typical Characteristics at a Hydraulic Operating Fluid Kinematic Viscosity of 46 mm<sup>2</sup>/s

A  
Piston Pumps

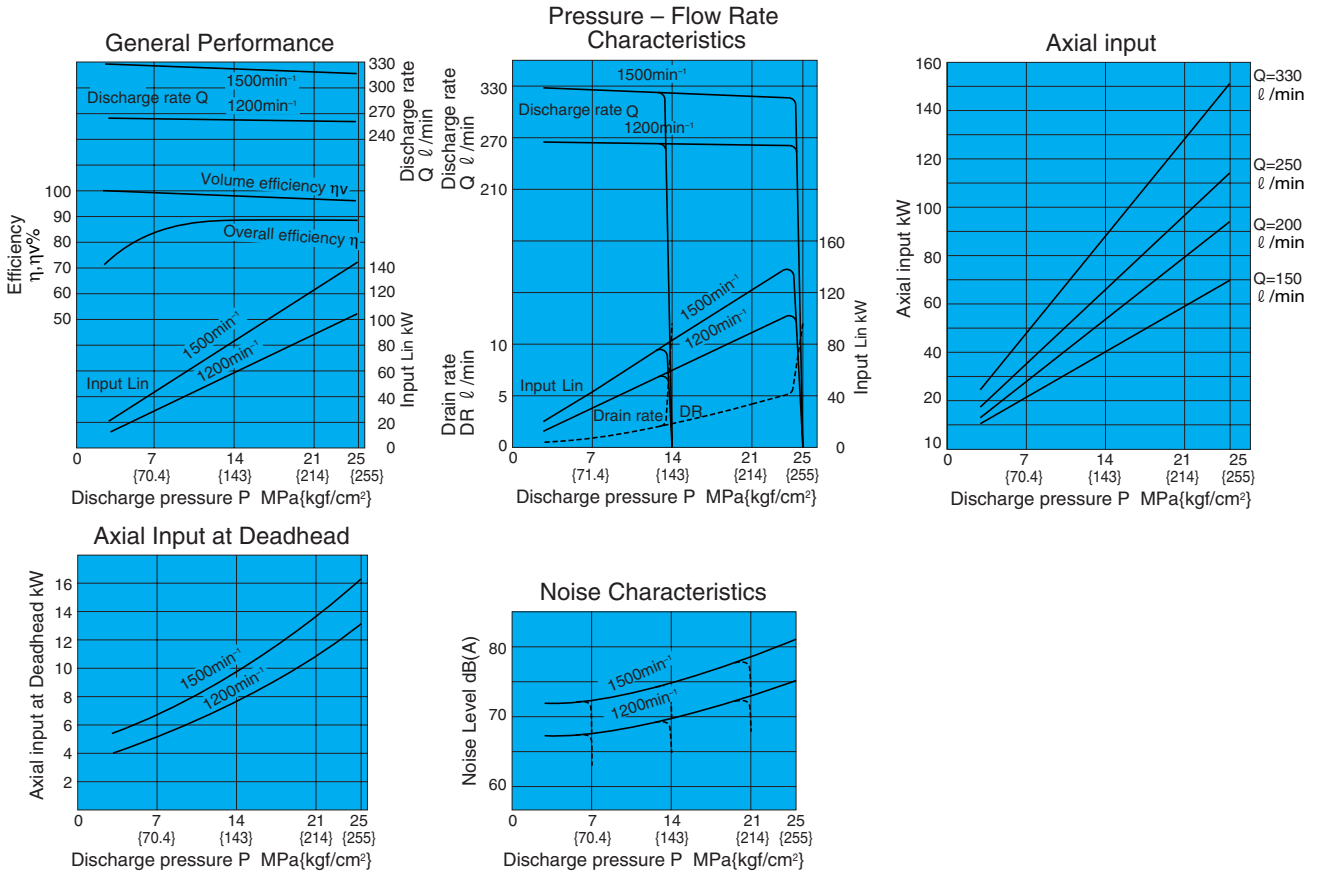

**Cross-sectional Drawing**

PZS-3B-70N\*-10  
PZS-4B-100N\*-10  
PZS-6B-\*\*N\*-10

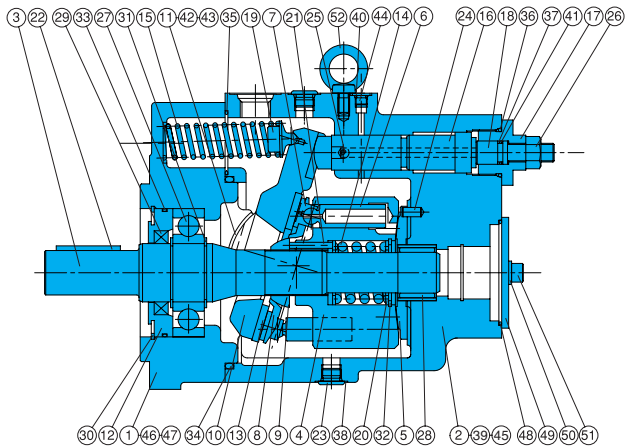

Part No.	Part Name	Part No.	Part Name
1	Body	28	Needle bearing
2	Case	29	Oil seal
3	Shaft	30	Snap ring
4	Cylinder barrel	31	Snap ring
5	Valve plate	32	Snap ring
6	Piston	33	O-ring
7	Shoe	34	O-ring
8	Shoe holder	35	O-ring
9	Barrel holder	36	O-ring
10	Swash plate	37	O-ring
11	Thrust bush	38	O-ring
12	Seal holder	39	O-ring
13	Thrust plate	40	O-ring
14	Spring C	41	Backup ring
15	Spring S	42	Orifice
16	Control piston	43	Flat philips head screw
17	End plug	44	Plug
18	Guide screw	45	Pin
19	Spring holder	46	Bolt
20	Retainer	47	Plug
21	Needle	48	O-ring
22	Key	49	Plate
23	Plug	50	Washer
24	Pin	51	Bolt
25	Orifice	52	Eye bolt
26	Nut		
27	Ball bearing		

List of Sealing Parts (Kit Model Number 3B : PZBS-103000, 4B : PZAS-104100, 6B : PZBS-106000)

Part No.	Name	Product Number				Remarks			
		PZS-3B	Q'ty	PZS-4B	Q'ty		PZS-6B	Q'ty	
29	Oil seal	TCN-456812	1	TCN-507212	1	TCN-659013	1	NOK	
33	O-ring	1B-G95	1	1B-G105	1	1B-G135	1	JIS B 2401	
34	O-ring	1B-G130	1	1B-G155	1	1B-G200	1	"	
35	O-ring	1B-G50	1	1B-G50	1	1B-G65	1	"	
36	O-ring	1B-P34	1	1B-P36	1	1B-P41	1	"	
37	O-ring	1B-P12	1	1B-P16	1	1B-P16	1	"	
*	38	O-ring	1B-P14	2	1B-P14	3	1B-P14	3	"
	39	O-ring	Note 1	1	1B-P9	1	1B-P10	1	"
	40	O-ring	1B-P8	5	1B-P8	5	1B-P8	8	"
	41	Backup ring	T2-P12	1	T2-P16	1	T2-P16	1	JIS B 2407
	48	O-ring	Note 1	1	1B-G85	1	1B-G85	1	JIS B 2401

Note 1: Contact your agent about this type of O-ring. \* Hydraulic fluid input changed to GPF 3/8. (from May 2008)

PZS-5B-130N\*-10

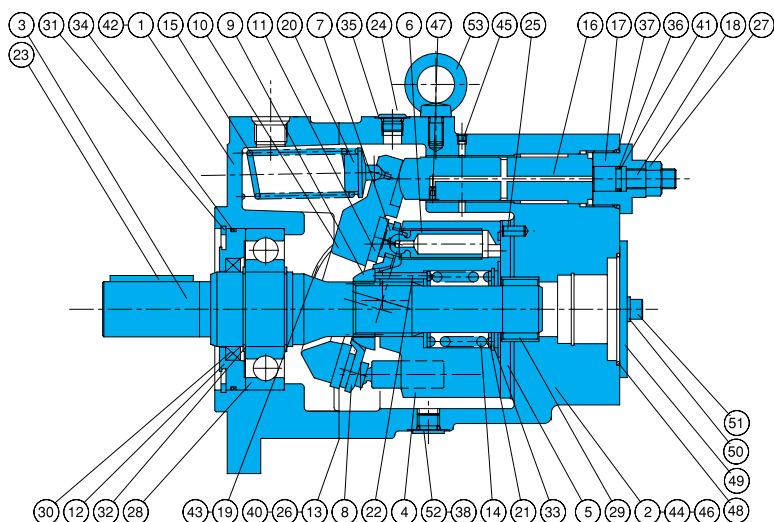

Part No.	Part Name	Part No.	Part Name
1	Body	28	Ball bearing
2	Case	29	Needle bearing
3	Shaft	30	Oil seal
4	Cylinder barrel	31	Snap ring
5	Valve plate	32	Snap ring
6	Piston	33	Snap ring
7	Shoe	34	O-ring
8	Shoe holder	35	O-ring
9	Barrel holder	36	O-ring
10	Swash plate	37	O-ring
11	Thrust plate	38	O-ring
12	Seal holder	39	O-ring
13	Gasket	40	O-ring
14	Spring C	41	Backup ring
15	Spring S	42	Bolt
16	Control piston	43	Flat philips head screw
17	End plug	44	Plug
18	Guide screw	45	Plug
19	Thrust bush	46	Plug
20	Spring holder	47	Orifice
21	Retainer	48	O-ring
22	Needle	49	Plate
23	Key	50	Washer
24	Plug	51	Bolt
25	Pin	52	Plug
26	Connector	53	Eye bolt
27	Nut		

PZS-5B (Kit Model Number 5B : PZAS-104000)

Part No.	Name	Q'ty	Size	Remarks
13	Gasket	1	*	3 Bond
30	Oil seal	1	TCN-608212	N. O. K
34	O-ring	1	1B-G125	JIS B 2401
35	O-ring	2	1B-P14	JIS B 2401
36	O-ring	1	1B-P16	JIS B 2401
37	O-ring	1	1B-P42	JIS B 2401
38	O-ring	1	1B-P14	JIS B 2401
39	O-ring	5	1B-P8	JIS B 2401
40	O-ring	2	1B-P7	JIS B 2401
41	Backup ring	1	T2-P16	JIS B 2407
48	O-ring	1	1B-G85	JIS B 2401

Parts marked by an asterisk "\*" are not available on the market. Consult your agent.  
 \* Lubrication port changed to GPF 3/8. (from May 2008)

**Pressure Compensator**

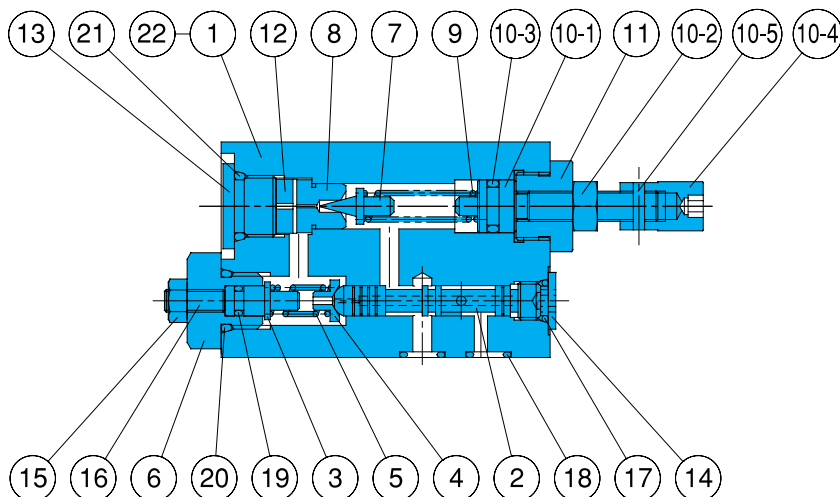

Part No.	Part Name	Part No.	Part Name
1	Valve body	12	Collar
2	Spool	13	Plug
3	Spring guide	14	Plug
4	Spring bearing	15	Nut
5	Spring	16	Socket head screw
6	Retainer	17	O-ring
7	Needle valve	18	O-ring
8	Valve seat	19	O-ring
9	Spring	20	O-ring
10	Adjustment screw kit	21	O-ring
10-1	Adjustment screw	22	Plug
10-2	Nut		
10-3	O-ring		
10-4	Nut		
10-5	Spring pin		
11	Retainer		

List of Sealing Parts

Part No.	Name	Part Number				Remarks
		PZS-3B, 4B	Q'ty	PZS-5B, 6B	Q'ty	
10-3	O-ring	1B-P10A	1	1B-P10A	1	JIS B 2401
17	O-ring	1B-P8	1	1B-P11	2	"
18	O-ring	1B-P9	4	1B-P9	5	"
19	O-ring	1B-P5	1	1B-P14	1	"
20	O-ring	1B-P12	1	1B-P22	1	"
21	O-ring	1B-P14	1	1B-P14	1	"

**Foot Mounting Kit**

Foot Mounting Installation Measurement Chart  
IHM-55-10

PZM-\*-10

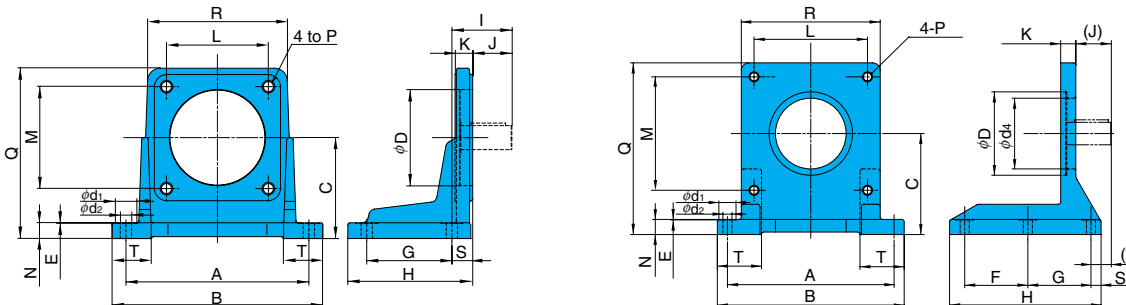

Foot Mounting Kit Model No.	Applicable Pump Model No.	Accessories				Measurements (mm)							
		Bolt	Q'ty	Washer	Q'ty	A	B	C	E	F	G	H	(I)
PZM-3-10	PZS-3B	TH-16x40	4	WP-16	4	295.3	334	152.4	1	-	139.7	203	104.5
PZM-4-10	PZS-4B	TH-20x45	4	WP-20	4	290	334	160	1	-	135	198	95
IHM-55-10	PZS-5B, 6B	TH-20x50	4	WS-B-20	4	330	370	200	1	125	125	300	40

Foot Mounting Kit Model No.	Measurements (mm)														Weight kg
	(J)	K	L	M	N	P	Q	R	(S)	T	φD	φd <sub>1</sub>	φd <sub>2</sub>	φd <sub>4</sub>	
PZM-3-10	60	25	128	128	25	M16	259	-	44.5	61	127	35	18	86	13.5
PZM-4-10	62	28	161.6	161.6	25	M20	270	220	33	62	152.4	34	18	φ152.4	18.0
IHM-55-10	70 (Note)	30	224.6	224.6	30	M20	340	275	20	90	165.1	34	18	140	32.0

Note The IHM-55-10 (J) dimension (70) is the value for the PZS-5B. This dimension becomes 58 in the case of the PZS-6B.  
The IHM-55-10 (I) dimension (40) is the value for the PZS-5B. This dimension becomes 28 in the case of the PZS-6B.  
See the IHM-45-10 on pages B-36 and C-12 to see what the PZM-3-10 looks like.

**Piping Flange Kit**

Screw In Type

Screw In Type Flange Kit model No.	Applicable Pump Model No.	IN Flange							
		Flange Part No.	Bolt	Washer	O-ring				
PJF-10300T	PZS-3B	IH03J-100120	1	TH-12x55	4	WS-B-12	4	1B-G50	1
PJF-10400T	PZS-4B	IH03J-100160	1	TH-12x60	4	WS-B-12	4	1B-G60	1
PJF-10500T	PZS-5B	IH03J-100200	1	TH-12x65	4	WS-B-12	4	1B-G75	1
PJF-10600T	PZS-6B	IH03J-100240	1	TH-16x75	4	WS-B-16	4	1B-G85	1

OUT Flange							
Flange Part No.	Bolt	Washer	O-ring				
IH03J-100100	1	TH-10x55	4	WS-B-10	4	1B-G40	1
IH03J-100160	1	TH-12x60	4	WS-B-12	4	1B-G60	1
IH03J-100200	1	TH-12x65	4	WS-B-12	4	1B-G75	1
IH03J-100200	1	TH-12x65	4	WS-B-12	4	1B-G75	1

Welded Type

Welded Type Flange Kit model No.	Applicable Pump Model No.	IN Flange							
		Flange Part No.	Bolt	Washer	O-ring				
PJF-10300E	PZS-3B	IH03J-200120	1	TH-12x55	4	WS-B-12	4	1B-G50	1
PJF-10400E	PZS-4B	IH03J-200160	1	TH-12x60	4	WS-B-12	4	1B-G60	1
PJF-10500E	PZS-5B	IH03J-200200	1	TH-12x75	4	WS-B-12	4	1B-G75	1
PJF-10600E	PZS-6B	IH03J-200240	1	TH-16x75	4	WS-B-16	4	1B-G85	1

OUT Flange							
Flange Part No.	Bolt	Washer	O-ring				
IH03J-200100	1	TH-10x55	4	WS-B-10	4	1B-G40	1
IH03J-200160	1	TH-12x60	4	WS-B-12	4	1B-G60	1
IH03J-200200	1	TH-12x65	4	WS-B-12	4	1B-G75	1
IH03J-200200	1	TH-12x65	4	WS-B-12	4	1B-G75	1

- See page C-11 for dimensions.
- O-ring 1B-\*\* refers to JIS B2401-1B-\*\*.
- See page C-11 for details on tightening torque.